

MCS

INDUSTRIAL INKJET TECHNOLOGY

MCS HAYABUSA

1,000 fpm Print Head



MCS Hayabusa Inkjet

Inkjet Over 2,000 Letters Per Minute

MCS Hayabusa

Wide format 8 1/2" inkjet

- **Ultra-High-Speed** - Page printing at over 1,000 fpm (1 up 8 1/2 x 11)
- **Ease of Use** - Low maintenance and simple to use
- **Ink Flexibility** - Inks for porous, coated and even aqueous coated stocks (over 10 black inks)
- **Workflow** - Supports PDF and IJPDS
- **600 dpi quality**

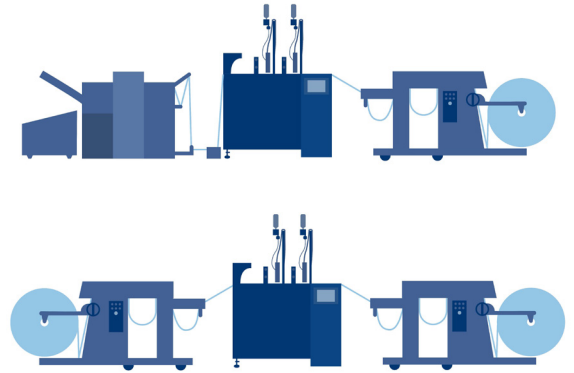

The Hayabusa can be mounted on a number of different industrial production lines including:

- MCS TK17 Web Transport - handling up to 12pt coated stocks
- Stand-Alone Roll to Roll
- Roll to Cut and Fold
- Existing Printing Presses

More Ink Options

- Eagle AS100 Ink – Surpasses UV and solvent based inks with higher reliability and performance at a lower operational cost.
- Dye, pigment & polymer ink formulas available. Print on porous, coated and even aqueous coated stocks - over 10 inks sets available!
- Users are able to change ink formulas between jobs with the Eagle systems.

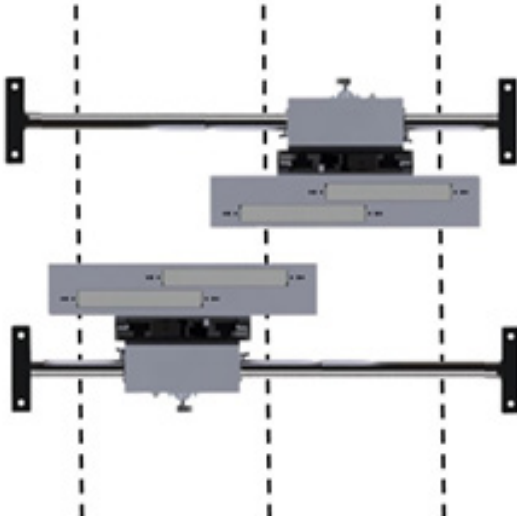

Workflow Options

MCS offers three different workflow options, Raptor, and an optional spooled PDF and IJPDS workflow. MCS spooled workflows work with most industry standard document composition software

Low Imaging Cost

Inkjet technology is quickly replacing toner technology because of the low operational cost. A piezo inkjet typically has a 50 to 75% lower running cost compared to traditional high-speed toner imaging cost.

High Production Speeds

The MCS Hayabusa 8 1/2" print head can print at speeds as fast as 1,000 feet per minute. On a two up application for letters that's over 2,000 letters per minute.

The Hayabusa is ideal for:

- Letters
- Labels
- Forms

MCS HAYABUSA	Pages Per Hour	Feet Per Minute
600 dpi – 2 up 8 1/2 x 11 letters	87,316 pph	667 fpm
400 dpi – 2 up 8 1/2 x 11 letters	130,909 pph	1,000 fpm
300 dpi – 2 up 8 1/2 x 11 letters	174,502 pph	1,333 fpm



Why MCS?

Founded in 1991, MCS is the leading manufacturer of industrial DOD (drop on demand) inkjet systems used in the mail manufacturing industry worldwide. MCS is heavily involved in many areas of the mail manufacturing industry including inkjet addressing systems, high-speed page printing systems, and high-speed inserting systems.



Corporate Office : 8101 Cessna Ave, Gaithersburg, MD 20879
Midwest Office : 694 Veterans Parkway, Unit H, Bolingbrook, IL 60440
Call 800-728-0154 www.mcspro.com